

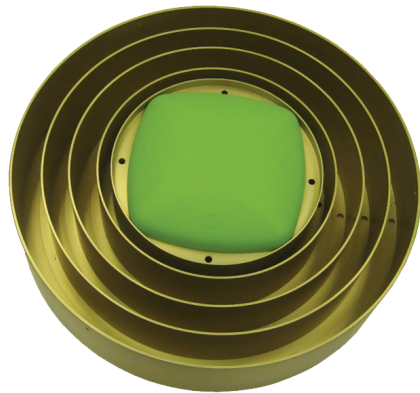

GNSS ANTENNA

## RingAnt-G3T



RingAnt-G3T is our GrAnt antenna mounted on our own choke ring. This makes our GrAnt antenna field upgradeable to choke ring type. The antenna cable can be connected via the standard TNC (N-type optional) connector on its side.

J-Shield is our filter that protects GPS L1, Galileo L1 and GLONASS L1 bands. It brings in all the useful signals intact and rejects out of band signals with the slope of about 12 dB/Mhz.

Similarly, it is our filter that protects GPS L2, GPS L5, GLONASS L2, GLONASS L3, and Galileo L5 and has slope of about 9 dB/MHz.

These filters have been extensively tested with five different innovative tests and prove that the filters also improve the performance of GNSS receivers.

RingAnt-G3T can track GPS, GLONASS, Galileo, BeiDou, WAAS, EGNOS, MSAS, GAGAN and QZSS signals.

# RingAnt-G3T

	G3T	G3T-JS	G3T+
<b>SIGNAL</b>			
Capability	GPS L1/L2/L2C/L5 GLONASS L1/L2/L3 GALILEO E1/E2/E5ab BEIDOU B1/B2 WAAS L1/L5, EGNOS, MSAS, GAGAN QZSS L1/L2/L2C/L5	GPS L1/L2/L2C/L5 GLONASS L1/L2/L3 GALILEO E1/E5ab WAAS L1/L5, EGNOS, MSAS, GAGAN QZSS L1/L2/L2C/L5	GPS L1/L2/L5 GLONASS L1/L2/L3 GALILEO E1/E5ab BEIDOU B1/B2 WAAS L1/L5, EGNOS, MSAS, GAGAN QZSS L1/L2/L5
Frequency, MHz	1551~1614 1164~1254	1565~1610 1164 ~1254	1555~1610 1164 ~1254
<b>ELECTRICAL</b>			
Antenna Gain, dB (typ.)	6.0 (1551~1614 MHz) 5.0 (1164~1254 MHz)	6.0 (1565~1610 MHz) 5.0 (1164~1254 MHz)	6.0 (1555~1610 MHz) 5.0 (1164~1254 MHz)
Axial Ratio, dB (max.)	3.0		
Output Impedance, Ohm	50		
LNA gain, dB	32±2; 40±2 (optional)	33±3; 43±3 (optional)	
Noise Figure, dB ( typ.)	1.7	2.8	
DC voltage, VDC	3.0~15.0	4.5~15.0	
Current, mA (typ.) @ 5 V	45 52 (40 dB LNA gain)	90 97 (40 dB LNA gain)	
Power consumption, W (max)	0.68 0.78 (40 dB LNA gain)	0.46 0.6 (40 dB LNA gain)	
<b>ENVIRONMENTAL</b>			
Operating Temperature, °C	-45 ~ +85		
Storage Temperature, °C	-50 ~ +85		
Humidity	Waterproof, 100% non-condensing, IP68		
Shock	Survives a 0.5 m drop onto a hard surface		
<b>MECHANICAL</b>			
Antenna type	Microstrip		
Connector	TNC; N-type (optional). The tightening torque for the coaxial connector nuts that secure the RF cable to the TNC type of RF connector must be 4.1 - 6.1 in-lbs (0.46 - 0.69 NM)		
Weight, kg	2.7		
Dimensions, mm	Ø326; h=88		
Enclosure	Radome: ABS; Base: Aluminum		
Mounting	5/8-11 inches mount		

# RingAnt-G3T

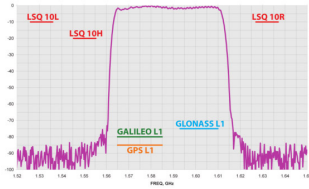

Frequency response of J-Shield filter for GPS L1, Galileo E1, and GLONASS L1 bands.

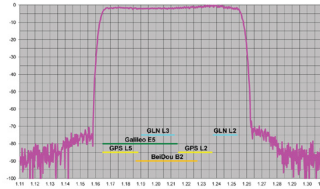

Frequency response of J-Shield and RingAnt-G3T+ filter for GPS L2, GPS L5, GLONASS L2, GLONASS L3, and Galileo E5.

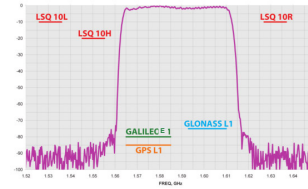

Frequency response of RingAnt-G3T+ filter for GPS L1, Galileo E1, and GLONASS L1 bands.

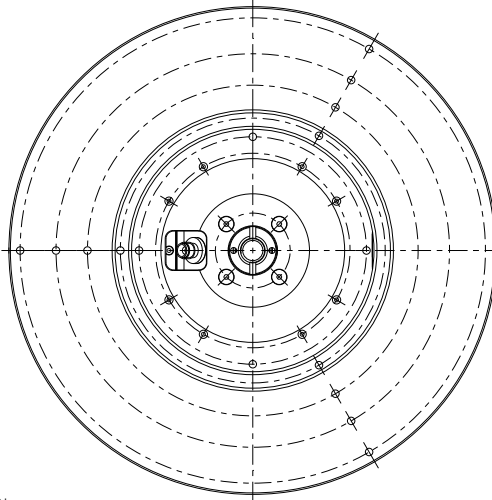
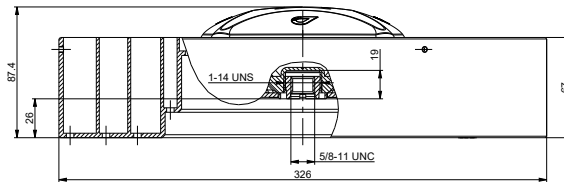
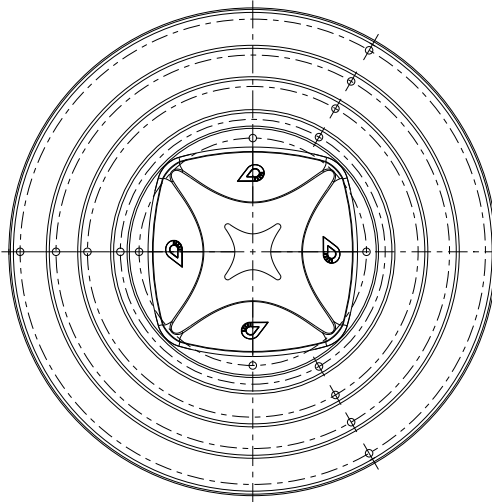

Antenna Code	Radome Code
JAVRINGANT_G3T	NONE
JAV_RINGANT_G3T	NONE

1. Dimensions are in millimeters.
2. Third angle projection.
3. All dimensions for reference only.
4. Approximate assembly weight is 2.709 kg.

# RingAnt-G3T

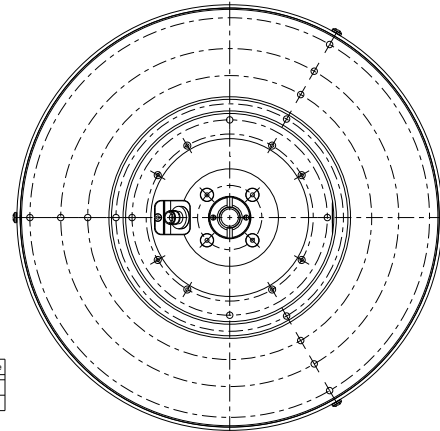
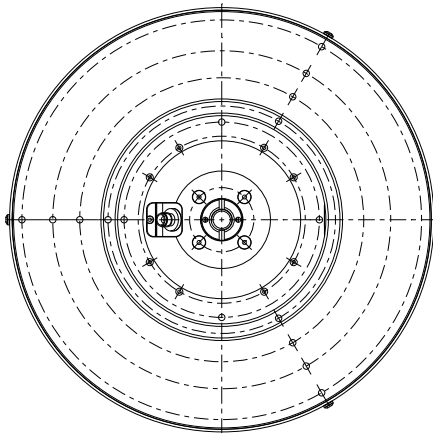
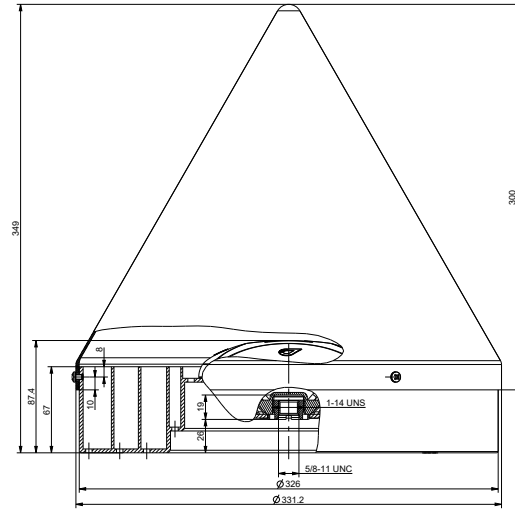
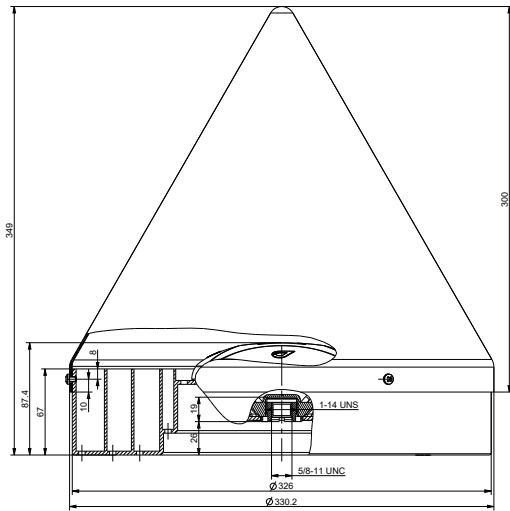

Antenna Code	Radome Code
JAVRINGANT_GST	JAVD
JAV_RINGANT_GST	JAVD

Dimensions are in millimeters.  
 Third angle projection.  
 All dimensions for reference only.  
 Snow Cone: 04-570800-11, RingAnt-G3T Snow Cone.  
 Material: plastic. Color: glossy white.  
 Approximate assembly weight is 3.138 kg.

Antenna Code	Radome Code
JAVRINGANT_GST	JAVC
JAV_RINGANT_GST	JAVC

1. Dimensions are in millimeters.  
 2. Third angle projection.  
 3. All dimensions for reference only.  
 4. Snow cone: 04-570800-01, RingAnt-G3T Snow Cone.  
 Material: fiberglass plastic. Paint color - glossy white.  
 5. Approximate assembly weight is 3.135 kg.

Illustrations, descriptions and technical specifications are not binding and may change.  
 Version 2.6 from May 6, 2020



900 Rock Avenue  
 San Jose  
 CA 95131, USA

+1(408)770-1770  
 sales@javad.com  
 www.javad.com