



GNSS ANTENNA

## GrAnt



GrAnt is a versatile high performance antenna. It can be mounted on flat surfaces with four screws or mounted on standard poles (5/8-11 or 1-14 inches thread). The antenna cable can be connected via the standard TNC (N-type optional) connector on its side or routed through the center of the antenna for ultimate protection in harsh environments.

J-Shield is our filter that protects GPS L1, Galileo L1 and GLONASS L1 bands. It brings in all the useful signals intact and rejects out of band signals with the slope of about 12 dB/MHz.

Similarly, it is our filter that protects GPS L2, GPS L5, GLONASS L2, GLONASS L3, and Galileo L5 and has slope of about 9 dB/MHz.

These filters have been extensively tested with five different innovative tests and prove that the filters also improve the performance of GNSS receivers.

GrAnt can track GPS, GLONASS, Galileo, BeiDou, WAAS, EGNOS, MSAS, GAGAN and QZSS signals. An optional ground plane can be purchased to increase multipath mitigation.

	G3	G3T	G5T
<b>SIGNAL</b>			
Capability	GPS L1, GLONASS L1, GALILEO E1/E2, BEIDOU B1, WAAS L1, EGNOS, MSAS, GAGAN, QZSS L1	GPS L1/L2/L2C/L5, GLONASS L1/L2/L3, GALILEO E1/E2/E5ab, BEIDOU B1/B2, WAAS L1/L5, EGNOS, MSAS, GAGAN, QZSS L1/L2/L2C/L5	GPS L1/L2/L2C/L5, GLONASS L1/L2/L3, GALILEO E1/E2/E5ab/E6, BEIDOU B1/B2/B3, WAAS L1/L5, EGNOS, MSAS, GAGAN, QZSS L1/L2/L2C/L5/LEX
Frequency, MHz	1551~1614	1551~1614 1164~1254	1551~1614 1164~1300
<b>ELECTRICAL</b>			
Antenna Gain, dB (typ.)	5.0	5.0 (1551~1614 MHz) 4.0 (1164~1254 MHz)	5.0 (1551~1614 MHz) 4.0 (1164~1300 MHz)
Axial Ratio, dB (max.)	3.0		
Output Impedance, Ohm	50		
LNA gain, dB	32±2, 40±2 (optional)		
Noise Figure, dB ( typ.)	1.7		
DC voltage, VDC	3.0~15.0		
Current, mA (typ.) @ 5 V	25 32 (40 dB LNA gain )	45 52 (40 dB LNA gain)	45. 52 (40 dB LNA gain)
Power consumption, W (max)	0.38 0.48 (40 dB LNA gain)	0.68 0.78 (40 dB LNA gain)	0.68 0.78 (40 dB LNA gain)
<b>ENVIRONMENTAL</b>			
Operating Temperature, °C	-45 ~ +85		
Storage Temperature, °C	-50 ~ +85		
Humidity	Waterproof, 100% non-condensing, IP68		
<b>MECHANICAL</b>			
Antenna type	Microstrip		
Connector	TNC; N-type (optional). The tightening torque for the coaxial connector nuts that secure the RF cable to the TNC type of RF connector must be 4.1 - 6.1 in-lbs (0.46 - 0.69 NM)		
Weight, g	450	515	
Dimensions, mm	140 x 140 x 62		
Enclosure	Radome: ABS, Base: Aluminum		
Color	Green		
Mounting	5/8-11 or 1-14 inches mount, or 4 holes M5		

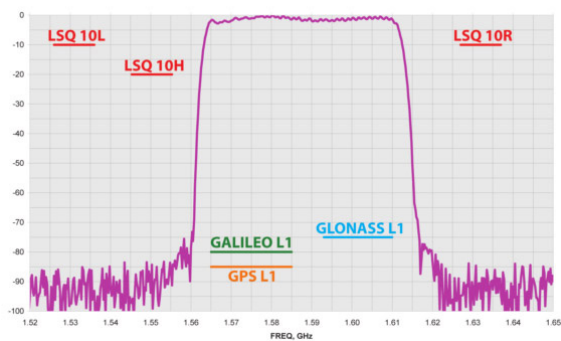

Frequency response of J-Shield filter for GPS L1, Galileo E1, and GLONASS L1 bands.

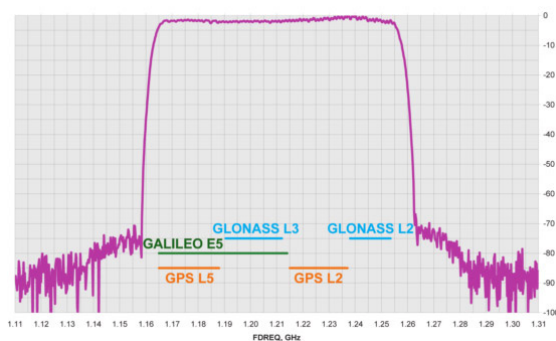

Frequency response of J-Shield filter for GPS L2, GPS L5, GLONASS L2, GLONASS L3, and Galileo E5

	G3-JS	G3+	G3T-JS	G3T+
<b>SIGNAL</b>				
Capability	GPS L1, GLONASS L1, GALILEO E1, WAAS L1, EGNOS, MSAS, GAGAN, QZSS L1	GPS L1, GLONASS L1, GALILEO E1, BEIDOU B1, WAAS L1, EGNOS, MSAS, GAGAN, QZSS L1	GPS L1/L2/L2C/L5, GLONASS L1/L2/L3, GALILEO E1/E5ab, WAAS L1/L5, EGNOS, MSAS, GAGAN, QZSS L1/L2/L2C/L5	GPS L1/L2/L2C/L5, GLONASS L1/L2/L3, GALILEO E1/E2/E5ab, BEIDOU B1/B2, WAAS L1/L5, EGNOS, MSAS, GAGAN, QZSS L1/L2/L2C/L5
Frequency, MHz	1565~1610	1555~1610	1565~1610 1164~1254	1555~1610 1164~1254
<b>ELECTRICAL</b>				
Antenna Gain, dB (typ.)	5.0		5.0 (1565~1610 MHz) 4.0 (1164~1254 MHz)	5.0 (1555~1610 MHz) 4.0 (1164~1254 MHz)
Axial Ratio, dB (max.)	3.0			
Output Impedance, Ohm	50			
LNA gain, dB	33±3 43±3 (optional)			
Noise Figure, dB (typ.)	2.8			
DC voltage, VDC	4.5~15.0			
Current, mA (typ.) @ 5 V	57 64 (40 dB LNA gain)		90 97 (40 dB LNA gain)	
Power consumption, W (max)	0.3 0.4 (40 dB LNA gain)		0.46 0.6 (40 dB LNA gain)	
<b>ENVIRONMENTAL</b>				
Operating Temperature, °C	-45 ~ +85			
Storage Temperature, °C	-50 ~ +85			
Humidity	Waterproof, 100% non-condensing, IP68			
<b>MECHANICAL</b>				
Antenna type	Microstrip			
Connector	TNC; N-type (optional). The tightening torque for the coaxial connector nuts that secure the RF cable to the TNC type of RF connector must be 4.1 - 6.1 in-lbs (0.46 - 0.69 NM)			
Weight, g	450		515	
Dimensions, mm	140 x 140 x 62			
Enclosure	Radome: ABS, Base: Aluminum			
Color	Green			
Mounting	5/8-11 or 1-14 inches mount, or 4 holes M5			

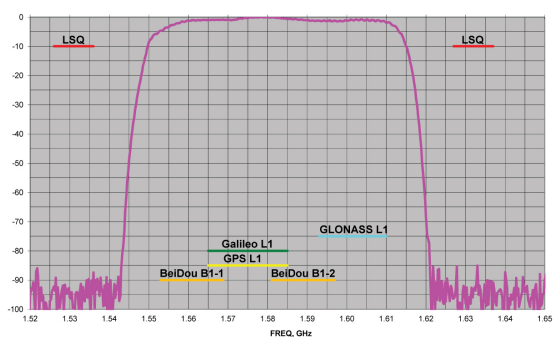

Frequency response of GrAnt-G3T+/GrAntG3+ filter for GPS L1, Galileo E1, and GLONASS L1 bands.

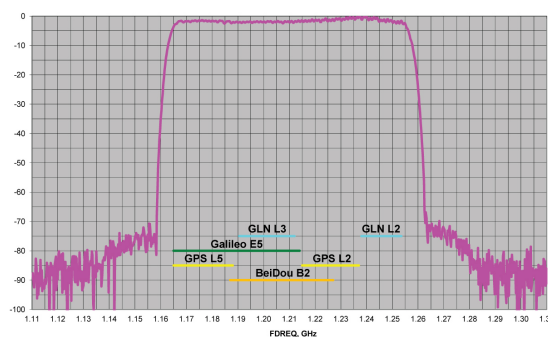

Frequency response of GrAnt-G3T+ filter for GPS L2, GPS L5, GLONASS L2, GLONASS L3, and Galileo E5

## DIMENSIONS

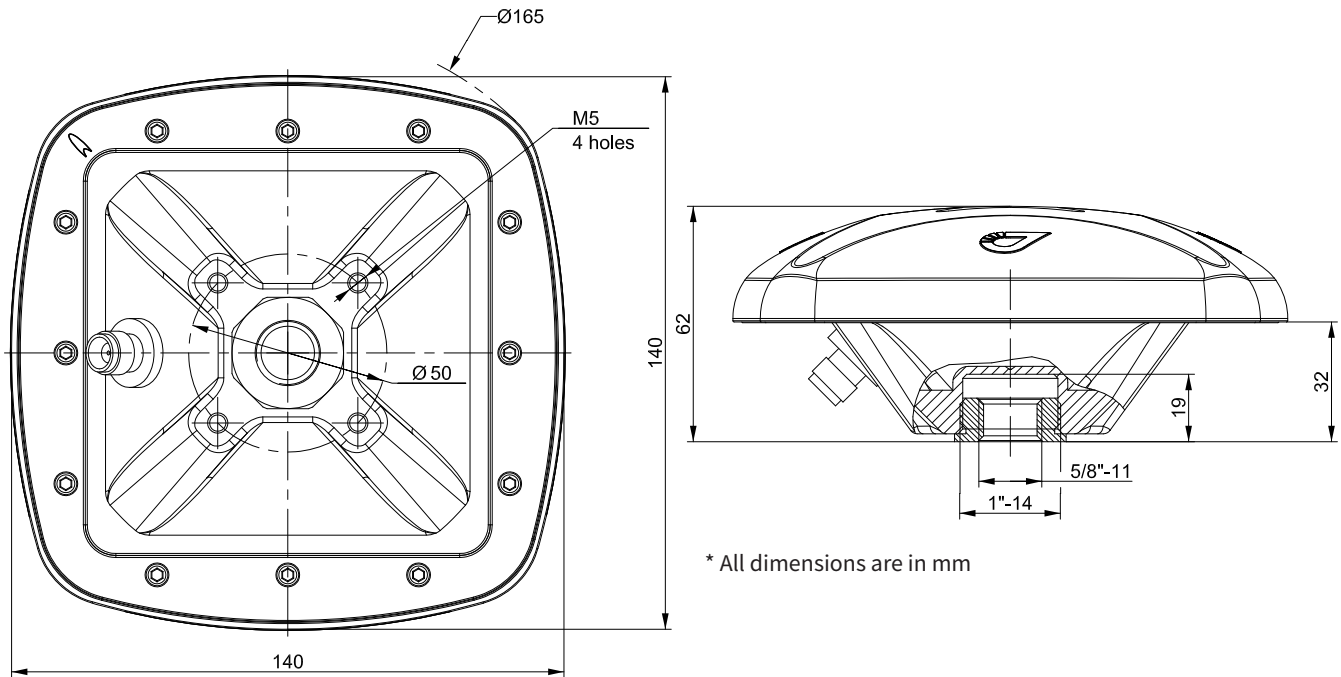

## RADIATION PATTERN

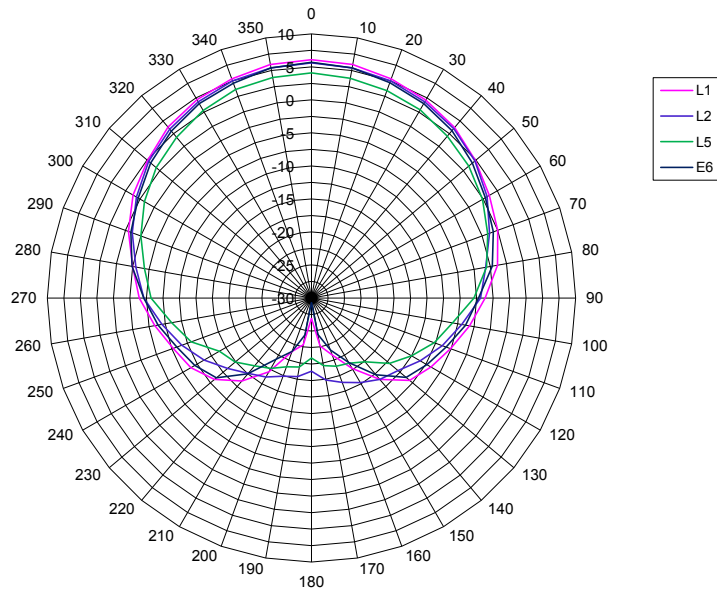

Illustrations, descriptions and technical specifications are not binding and may change.

Version 3.5 from October 22, 2019



900 Rock Avenue  
San Jose  
CA 95131, USA

+1(408)770-1770  
sales@javad.com  
www.javad.com